

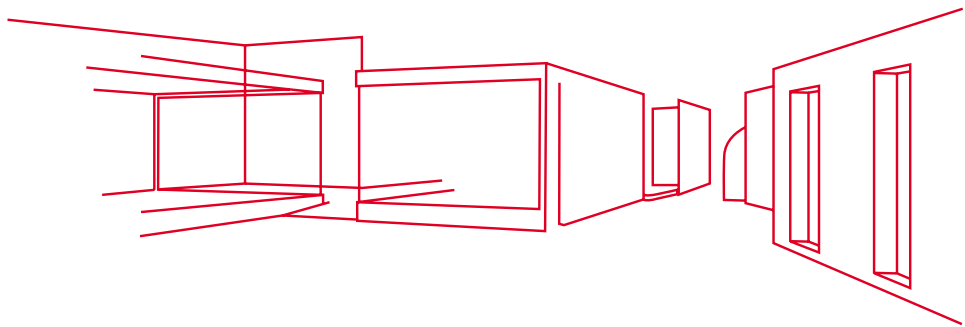

FLASH

PHOTOBITION





Company profile

Established in 1986, Flash Photobition has production facilities in Sydney, Melbourne, Brisbane and Canberra and is part of a global network with associated offices in Hong Kong, Tokyo, Los Angeles, New York, London, and other locations worldwide.

Flash directly employs more than 100 staff and has twice been nominated as one of Australia's top 100, fastest growing businesses.

Since its inception Flash Photobition has provided thousands of innovative graphic solutions for an extensive array of purposes such as: retail fit-outs, trade shows, exhibitions and museums, posters, billboards and point-of-sale.

Flash Photobition has the knowledge and technical capabilities that push the boundaries of graphics. We develop practical and innovative solutions that deliver high quality graphics with maximum impact.

Quality assurance

Our electronic job management system ensures all jobs are tracked at all stages of production. Every stage is entered time allocated, tracked and signed off throughout the production process to ensure jobs are delivered to schedule.

1. Create Job Sheet

Our Customer Support team creates a job sheet and enters all production phases for the project that includes instructions from the production brief provided by the Graphics Consultant. The Production Manager then lodges the job schedule with all relevant departments, to ensure that enough time has been allocated to each department to meet the agreed deadline.

2. Proof Check

After the client approves a proof on stock the Production Co-ordinator signs off on final prints prior to proceeding to the finishing stage. This ensures correct layout and colour matching has been achieved, against the supplied hard copy and signed-off proof.

3. Finishing of our printed products

Finishing of printed products may include a protective and enhancing coating, a laminate or the adhering of the prints to a substrate.

After completion all work is quality controlled and signed off prior to packaging and distribution.

4. Distribution and Handling

This includes collating prints and panels, combining all elements into containers, providing photos and instructions for end user if required, wrapping bulk and individual packages, producing address labels and organising couriers and freight. These tasks are handled by production and packing staff, and our Freight/Courier Manager. All freight and couriers are logged for tracking reference.

How we print

In 1986 Flash commenced business as a commercial photographic lab and today this is still one of the options we offer our clients. Photographic quality prints are still our driving passion.

Our background in the high end photographic industry forces us to strive for the ultimate quality regardless of the output device.

Today we can print to almost anything. Using our flatbed printers we can print direct to wood, metal, plastics and acrylic. In fact we can print to almost anything flat, regardless of shape.

Our super wide (5 metres) Vutek printer allows us to print huge building wraps, billboards and the large banners you see hanging outside galleries and museums around the country.



The new generation of Solvent HiRes Inkjet Printers enables us to produce almost photographic quality direct to vinyls, papers and backlit films.

Using Dye Sublimation printing devices we can print to a wide range of soft fabrics creating a washable graphic printed onto sheer, opaque and translucent fabrics.



And yes, we are still printing high quality photographic images directly from your digital files onto a range of materials, including photographic papers, metallic stock, DuraClear and DuraTrans backlit films.



We don't limit you to a single process, they all have their particular advantages.

Tell us what you want to achieve and we will help you choose the most suitable output method. Indoor or outdoor, a short term campaign or permanent museum installation, just let us know!

We will show you samples of printed materials and you will see how we have used these products in the past. Tailoring our range of services to match your needs is our speciality.



You're also welcome to visit our production facilities. There you will find exciting new creative solutions, in our showrooms or on a factory tour, you will virtually stumble onto your own creative ideas.





FREE CALL
1800 606 682
www.flash.com.au

Sydney

8 Guihen Street
Camperdown NSW 2050
T +61 2 8594 3555
F +61 2 9550 4271
E flash.aus@flash.com.au

Melbourne

146 Dudley Street
West Melbourne VIC 3003
T +61 3 9322 1600
F +61 3 9326 8000
E melbourne.vic@flash.com.au

Brisbane

58 McLachlan Street
Fortitude Valley QLD 4006
T +61 7 3620 7600
F +61 7 3252 1228
E brisbane.qld@flash.com.au

Canberra

61 Kembla Street
Fyshwick ACT 2609
T +61 2 6280 6166
F +61 2 6280 6177
E canberra.act@flash.com.au